

## ACCESSORY SETUP INSTRUCTION

### HALF DOOR ASSY -- PN 5ASV-807000-6000

VALID FOR: MY2021 and Newer UFORCE 600

**SETUP NOTE:** FOR ILLUSTRATION PURPOSES, THE LEFT HALF DOOR INSTALLATION IS SHOWN. THE ASSEMBLY STEPS OF THE RIGHT HALF DOOR ARE THE SAME.

**BEFORE YOU BEGIN:** Read and understand the instructions before starting any work. Make sure that all parts are ready and that you have all the tools required for assembly.

**NOTE:** CFMOTO shall not be liable for any damage caused by incorrect assembly. CFMOTO recommends that all original accessories be assembled by an authorized CFMOTO dealer.

Before assembly, park the vehicle on a flat surface, put the transmission gear into Park (P) and turn off the key switch.

**Zhejiang CFMOTO Power Co., Ltd.** All rights reserved. Reproduction of this document, even in part, as well as copying of all kinds, is permitted only with the express written permission of the copyright owner.

### MEANING OF SYMBOLS

 - Indicates information with more details or tips.

 - Indicates information of warning or danger.

### PARTS LIST:

ITEM	PART NAME	PART NUMBER	QTY.	REMARK
1	SIDE DOOR ASSY	5ASV-807000-6000	1	For structure reference only
2	LH HALF DOOR & RH HALF DOOR	5ASV-807310-6000 & 5ASV-807410-6000	1 & 1	
3	LH BUCKLE & RH BUCKLE	5ASV-807320-6000 & 5ASV-807420-6000	1 & 1	
4	CLAMP, LH CAB & CLAMP, RH CAB	5ASV-807301-6000 & 5ASV-807401-6000	1 & 1	
5	RUBBER GASKET, FRONT CLAMP	5ASV-807302-6000	1 & 1	
6	REAR CLAMP, CAB	5ASV-807303-6000	1 & 1	
7	RUBBER GASKET, REAR CLAMP	5ASV-807304-6000	1 & 1	
8	CLAMP	5ASV-807305-6000	1 & 1	
9	SCREW CAP, CLAMP	5ASV-807306-6000	1 & 1	
10	LH DOOR LOCK & RH DOOR LOCK	5ASV-807307-6000 & 5ASV-807407-6000	1 & 1	
11	LH DOOR LOCK KIT & RH DOOR LOCK KIT	5BWV-372060-5100 & 5BWV-374060-5100	1 & 1	
12	BRACKET ASSY, LH BUCKLE & BRACKET ASSY, RH BUCKLE	5ASV-372030-6000 & 5ASV-374030-6000	1 & 1	
13	LIMIT CABLE ASSY	5HY#-372050-1000	1 & 1	
14	LH UPPER CONNECTING PLATE ASSY & RH UPPER CONNECTING PLATE ASSY	5HY#-372500-1001 & 5HY#-372600-1001	1 & 1	
15	LH LOWER CONNECTING PLATE ASSY & RH LOWER CONNECTING PLATE ASSY	5ASV-807330-6000 & 5ASV-807430-6000	1 & 1	
16	DOOR LOCK BALL	5ASV-807300-6000-20	1 & 1	
17	LOCK NUT M8	30202-080170	2 & 2	
18	BOLT M6x14	8010-000004	2 & 2	
19	BOLT M8x16	30006-080016870	6 & 6	
20	HEX FLANGE BOLT M6x10	5ASV-807300-6000-21	4 & 4	
21	INNER HEX BOLT M8x16	5ASV-807300-6000-22	6 & 6	
22	HEX FLANGE BOLT M6x25	5ASV-807300-6000-23	2 & 2	
23	NUT M6	5ASV-807300-6000-24	2 & 2	
24	DAMPING RUBBER MAT	5ASV-807314-6000	3 & 3	
25	SCREW M8x25	30121-080025160	4 & 4	
26	BOLT M6x35	5ASV-807300-6000-25	1 & 1	
27	SHAFT SLEEVE	5ASV-807300-6000-26	1 & 1	

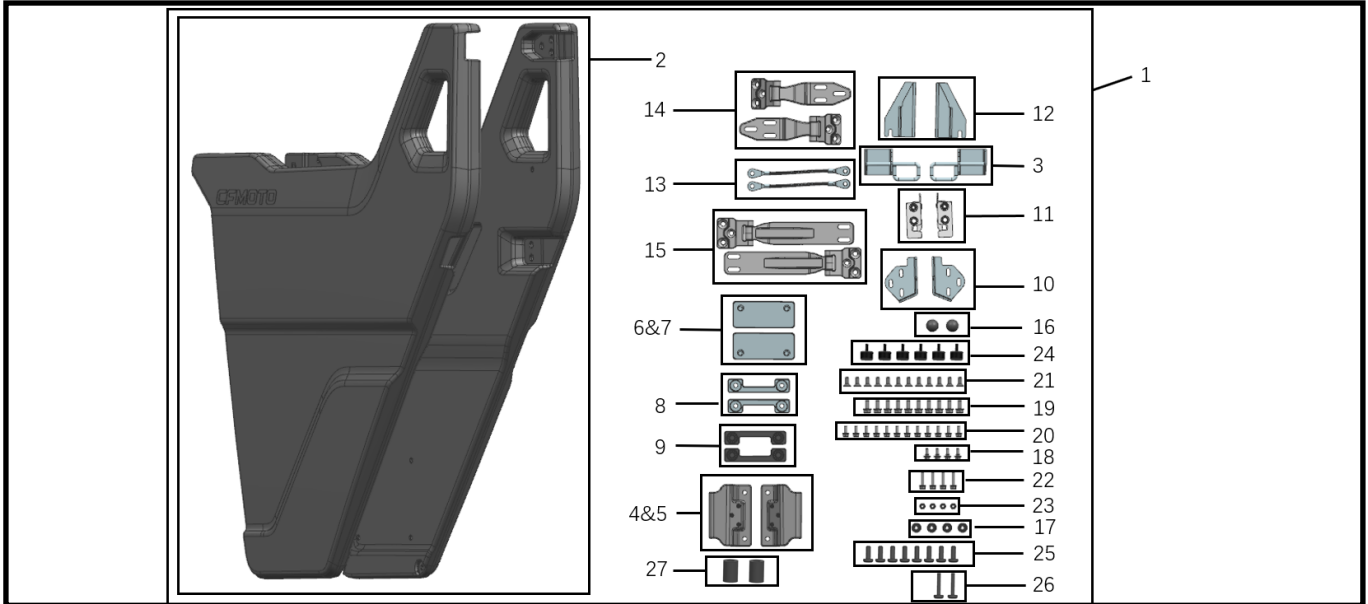

### TOOL LIST:

ITEM	DESCRIPTION	QTY.	REMARK
1	10mm WRENCH	1	Recommended tools
2	5mm ALLEN WRENCH	1	
3	13mm SLEEVE	1	
4	10mm SLEEVE	1	
5	ELECTRIC WRENCH	1	
6	PROTECTIVE GLOVES	1	

### ASSEMBLY AND INSTALLATION

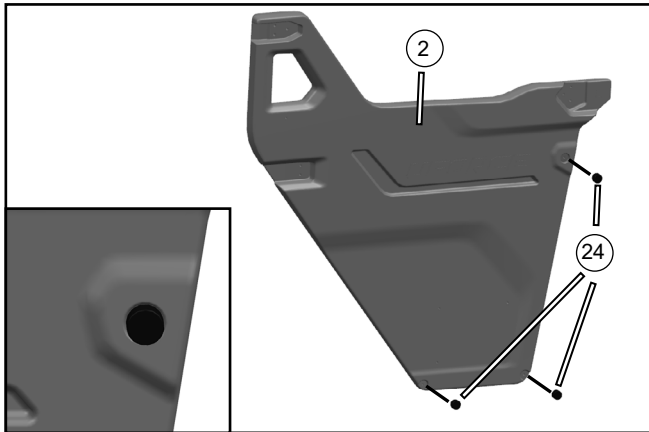

// Install three rubber mats (24) into the corresponding holes of the LH half door (2) at the locations shown.

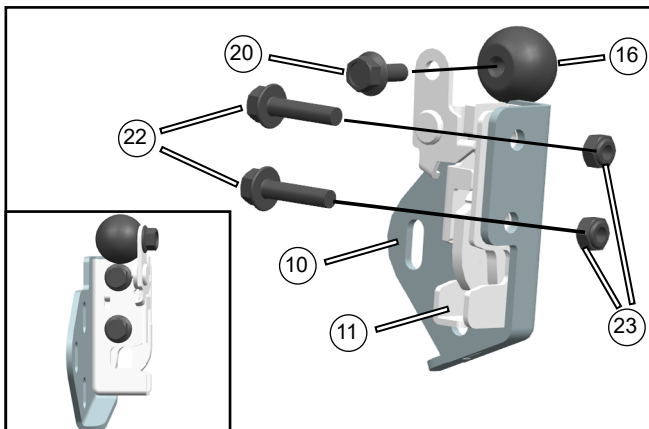

// Install door lock ball (16) on the lever hole of the LH door lock (11) using M6x12 hex flange bolt (20), then install the LH door lock (11) on the LH door lock bracket (10) using two M6x25 hex flange bolts (22) and two M6 nuts (23).

**i** - LH door lock kit (11) is installed on the RH door, and RH door lock kit (11) is installed on the LH door.  
 - Apply screw-thread glue between door lock ball (16) and hex flange bolt (20).

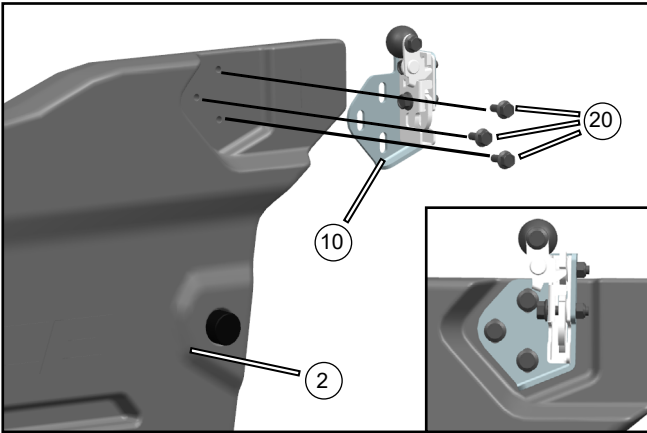
**ASSEMBLY AND INSTALLATION**

// Align the assembled LH door lock (10) with the corresponding holes on the LH half door (2) and install three M6x12 hex flange bolts (20).

**i** - Do not fully tighten the bolts at this time, so as to facilitate fine tuning of the door latch onto the LH Buckle (3).

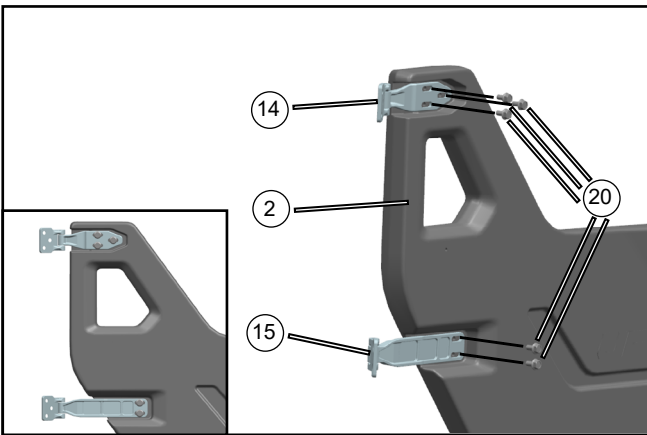

// Align the LH upper and lower connecting plate assemblies (14,15) with the corresponding holes on the LH half door (2) and install M6x12 hex flange bolts (20).

**i** - Do not fully tighten the bolts at this time, so as to facilitate fine tuning of the door fitment during installation on the vehicle.

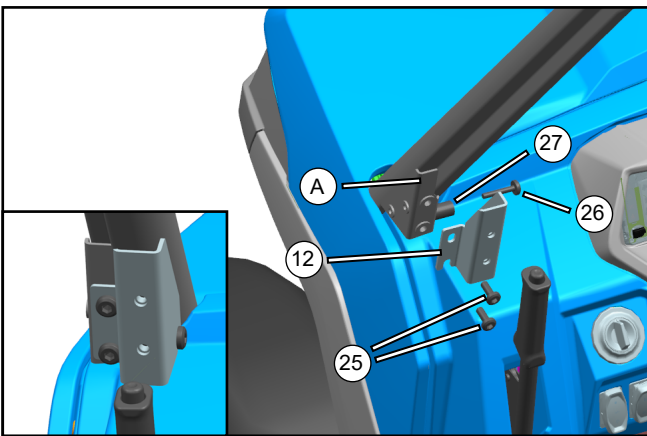

// Install the left buckle bracket assy (12) and shaft sleeve (27) on the frame cab (A) by M6x35 bolts (26), then install 2 M8x25 screws (25) onto the frame cab (A).

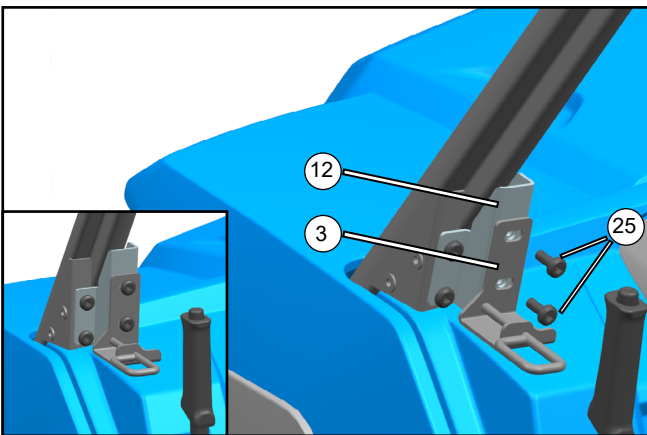

// Install the LH buckle (3) on the LH buckle bracket (12) using two M8x25 screws (25).

**i** - Do not fully tighten the bolts at this time, so as to facilitate fine tuning of the LH Buckle to match with the door lock.

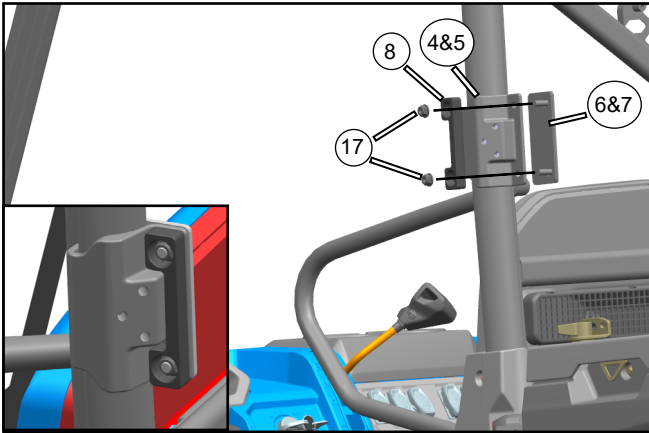
**ASSEMBLY AND INSTALLATION**

// Fasten the screw cap (9) to the clamp (8).re-install the LH rear cab clamp assembly (assembled by 4&5, 6&7, and 8) onto the rear cab frame using two M8 lock nuts

**i** - Do not fully tighten the lock nuts at this time, so as to facilitate fine tuning of the door fitment during installation on the vehicle.



// Fasten the screw cap (9) to the clamp (8).

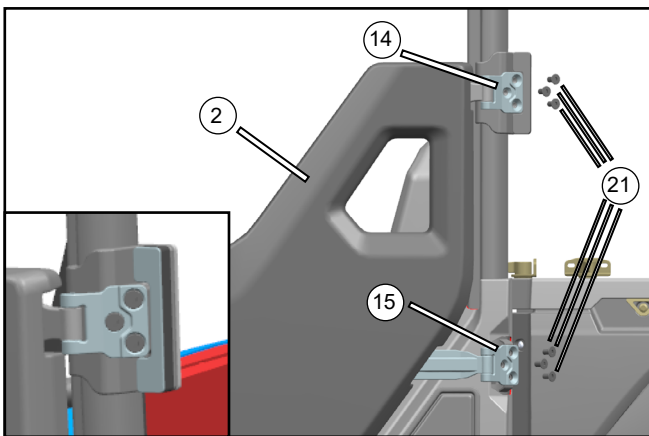

// Install the left upper connecting plate assy (14) and the left lower connecting plate assy (15) on the left half door (2) to the corresponding holes of the frame.

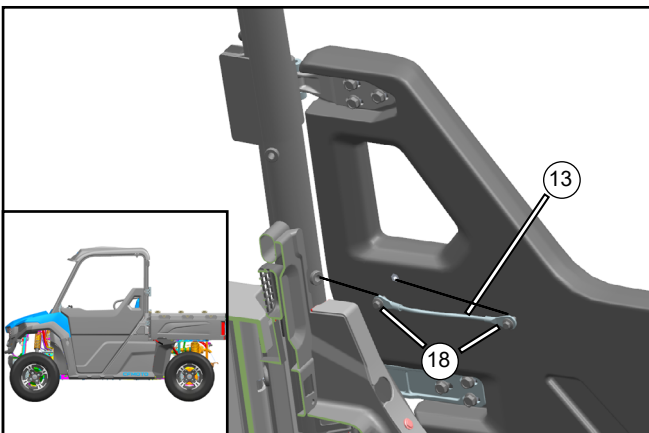

// Attach the limit cable assembly (13) to the LH half door and rear cab frame using two M6x14 bolts (18).

**i** - Assembly of the left half door is complete. The right half door is assembled in the same method.

**i** - Lock the half door first, then tighten the relevant bolts on the upper and lower connecting plates, door lock kits and buckle.